



# Switchback Stringer Installation Guide



## Tools Needed from the Installation Kit



Torque Wrench



1/2" to 3/8" Reducer



3/4" Socket



5/16" Hex Bit Socket



5/16" Hanger Bolt Driver

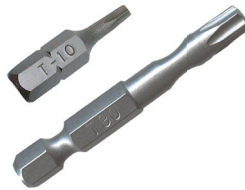

T-10 & T-30 Torx Bits



ThreadLocker

## Other Tools and Supplies Not Included in the Installation Kit

- Drill/Hammer Drill
- Impact Driver/Socket Wrench
- Pencil
- Level
- T-Square
- 3/8" Wood Drill Bit (*Wood Install Only*)
- 9/16" Concrete Drill Bit (*Concrete Install Only*)
- 11/16" Forstner Bit (*Wood Install Only*)
- Wood Glue
- Concrete Epoxy (*Concrete Install Only*)
- Silicone Sealant

## Things to Know Before You Get Started

- Read over the provided material prior to the start of your installation
- Ensure to apply the supplied Threadlocker to all mechanical connections



### Switchback Stringer Installation Steps



- Locate the stringers and measure them to make sure they match the prints provided to you during the engineering approval process

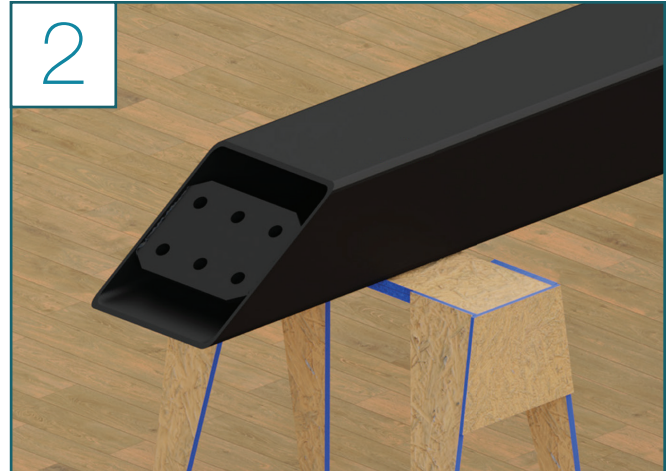

- Locate the stickers that indicate the “Foot” & “Head” sides of the stringer



- Identify and prepare the two halves of the hockey stick



- Using the access hole & provided bolts, attach the two sides of the hockey stick
- Torque to 70 lb-ft

Switchback Stringer Installation Steps (Continued)

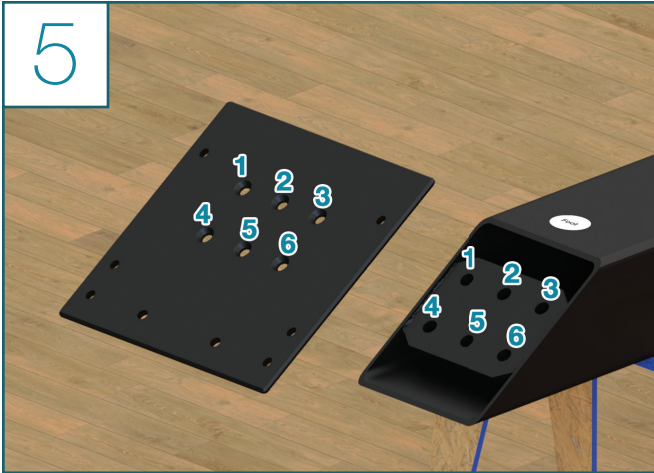

- Noting the “Foot” sticker, match the beveled Foot Plate holes to the Stringer holes

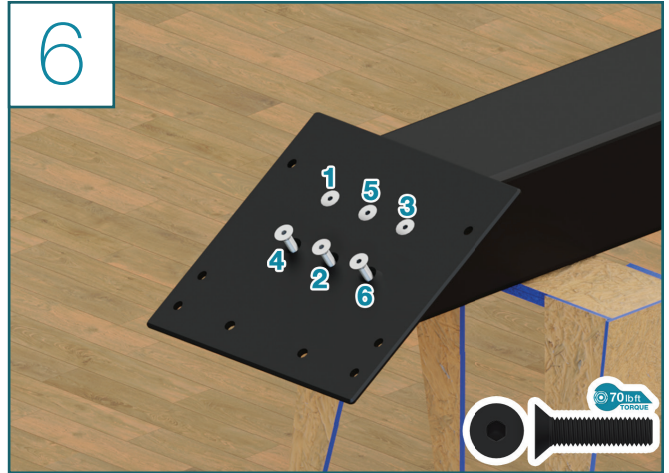

- Use the 1/2" x 2" Flathead Bolts to attach the floor plate to the stringer
- Torque to 70 lb-ft

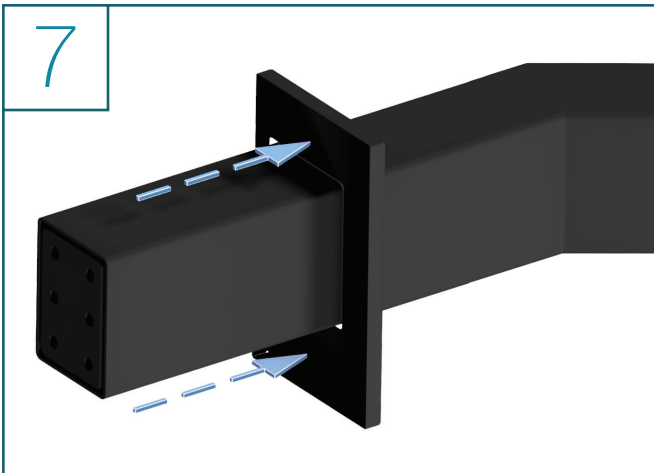

- Slide the cover plate over the stringer, paying attention to its orientation
- The thin section will end up on top of the stringer

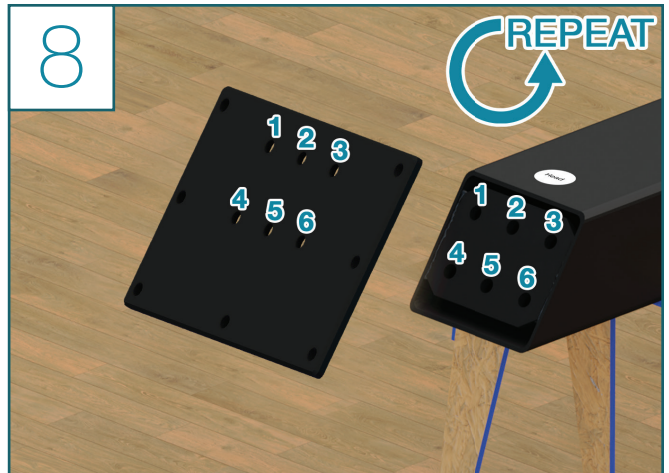

- Noting the “Head” sticker, match the beveled Header Plate holes to the Stringer holes
- Repeat Steps 5-6 for the Header Plate Bolts

### Switchback Stringer Installation Steps (Continued)

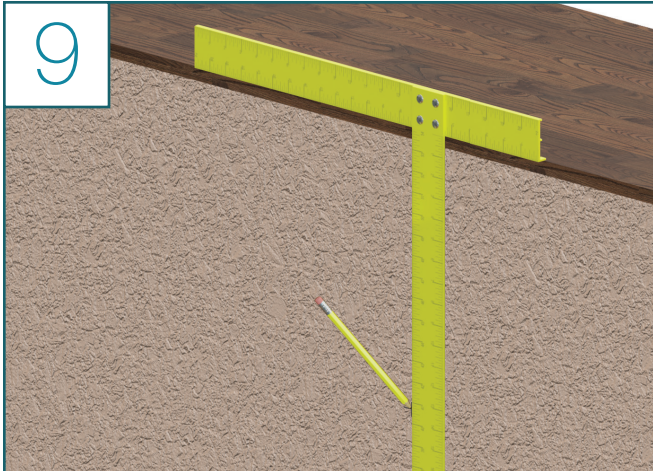

- Use the provided drawing(s) to mark the header plate dimensions
- At this point, mark a predrill location for the slotted hole in your header plate

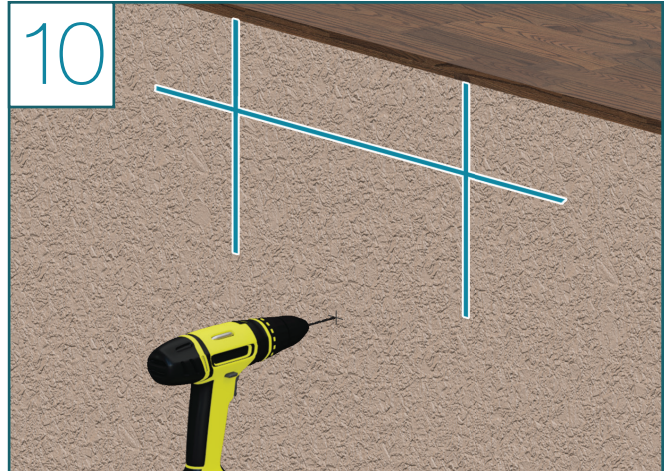

- Predrill with a 3/8" drill bit

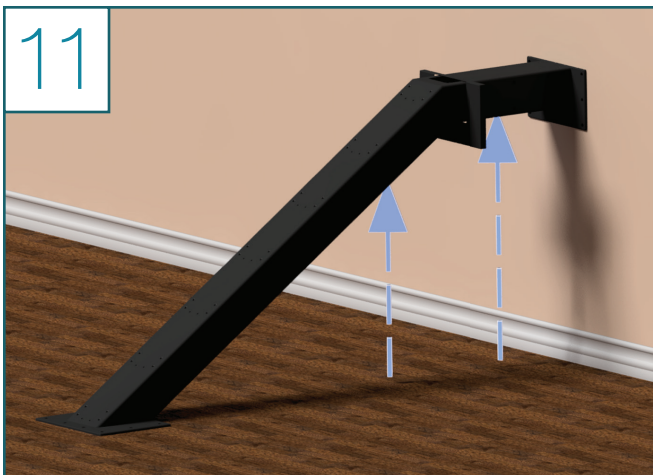

- Lift the stringer into place, lining up the hole

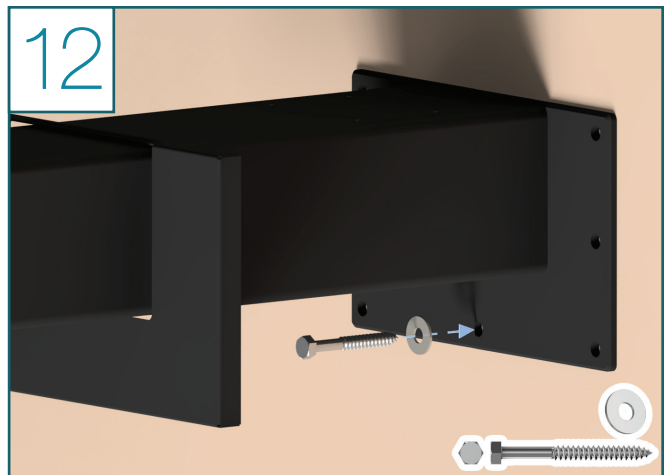

- Fasten the 1/2" x 3 1/2" Hex Lag through the middle slotted hole in the header plate to hold the stringer in place

### Switchback Stringer Installation Steps (Continued)

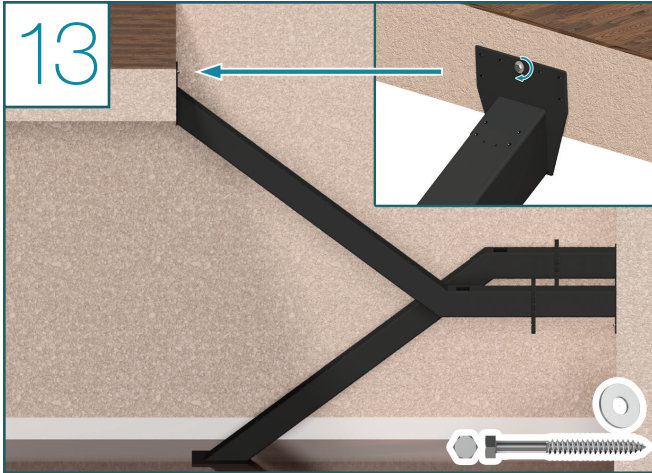

- Hoist the upper stringer into place
- We recommend using either a pulley system or a Come Along Winch and brace material to hold the stringer in place while fastening
- Fasten the 1/2" x 3 1/2" Hex Lag through the middle slotted hole in the header plate to hold the stringer in place
- Repeat this step for all landing mounting plates

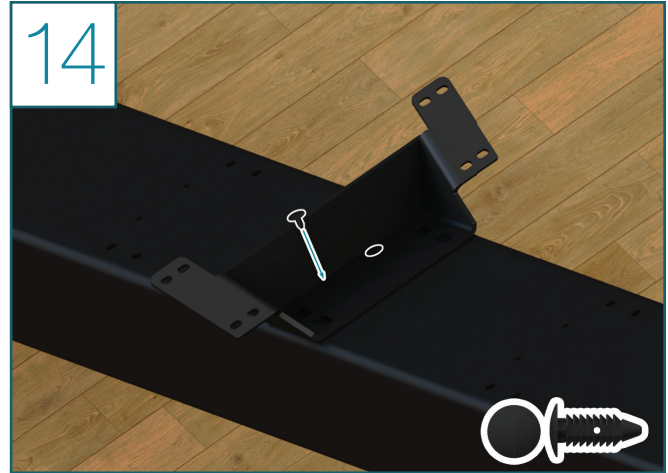

- Place all tread brackets on the lower stringer
- Insert Christmas Tree Rivets to hold the tread brackets in place

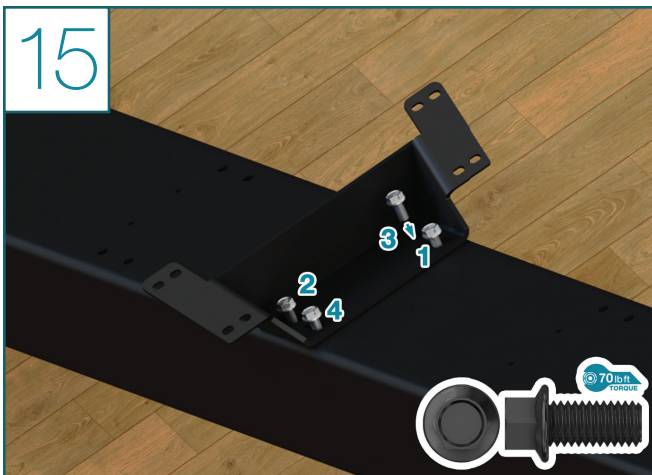

- Thread the 1/2" x 1" flange bolts through the tread bracket and into the stringer in the marked order, so they are finger tight
- Torque to 70 lb-ft



- Place a single tread on to one of the tread brackets about half-way up the stringer

Switchback Stringer Installation Steps (Continued)

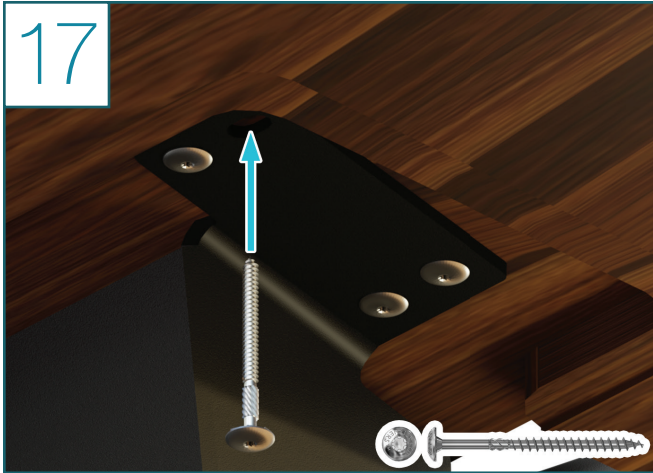

- Using the  $\frac{5}{16}$ " x  $2\frac{1}{2}$ " RSS Screws, attach the tread to the tread bracket
- During this step, alternate sides of the bracket when fastening screws. This will prevent the tread from pulling unevenly



- Ensure the tread is level on the tread bracket both front to back and left to right

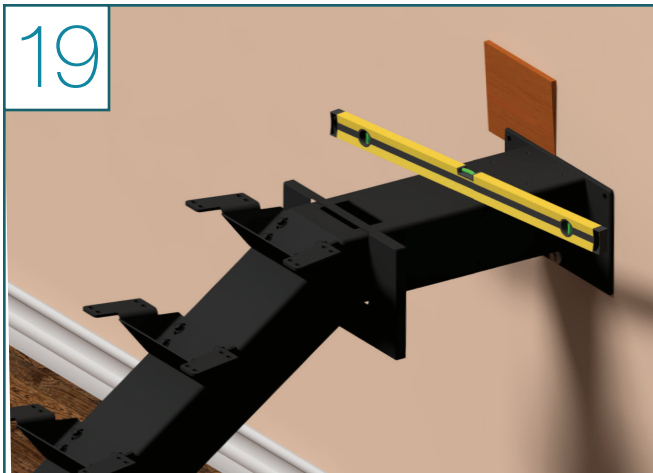

- If not level left to right, shim the header plate to adjust
- If not level front to back, shim the footer plate to adjust
- Cut the excess shim away
- Predrill through the header plate holes with a  $\frac{3}{8}$ " drill bit
- At this point, predrill all your header plate holes using a  $\frac{1}{2}$ " bit

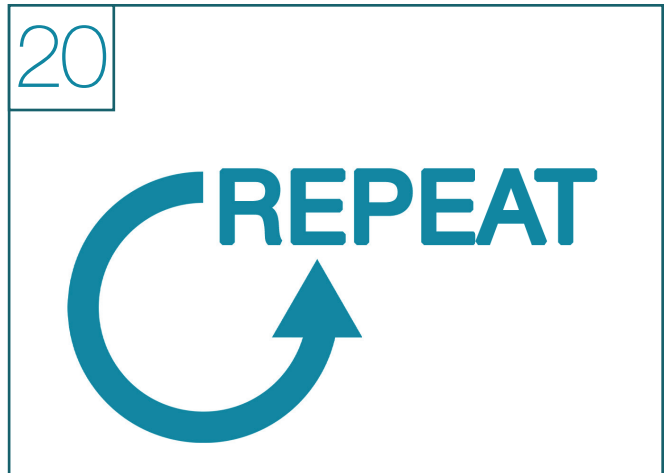

- Repeat Steps 14-19 for the upper stringer
- Only remove the winch when the header and footer are firmly fastened

### Switchback Stringer Installation Steps (Continued)

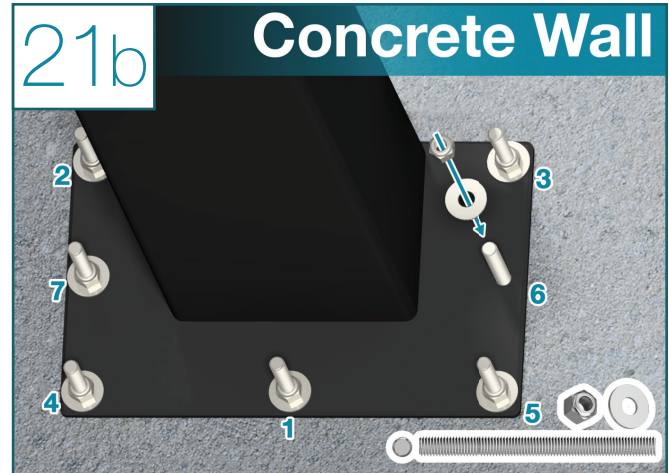
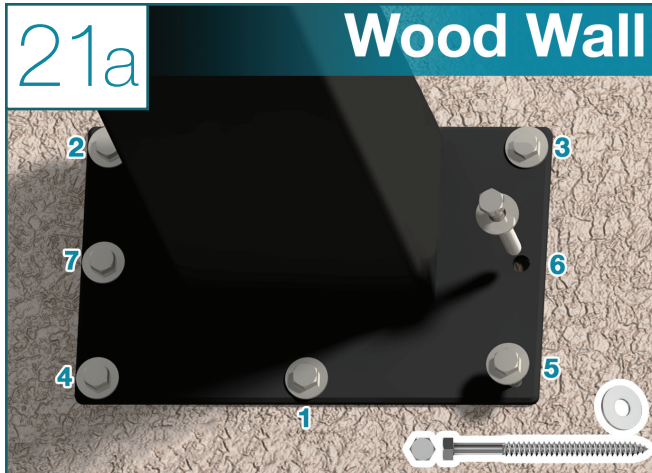

#### Lower & Upper Stringer Wall Mount

- Thread the 1/2" x 8" hex head bolts into place
- Do this for both
- Slide the cover over the wall plates, you may want to use a dab of silicone on each of the bolts

#### Lower & Upper Stringer Wall Mount

- Refer to the recommendation of the brand of epoxy you are using and predrill the correct sized holes for these 1/2" threaded studs
- Apply concrete epoxy in to the holes
- Insert the threaded studs into each hole
- Allow for the appropriate amount of curing time, for the epoxy, based off of the manufactured recommendations
- Slide the cover over the wall plates, you may want to use a dab of silicone on each of the bolts

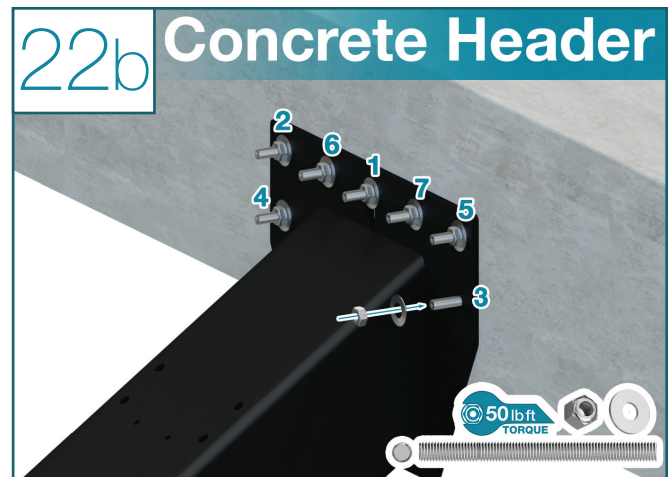
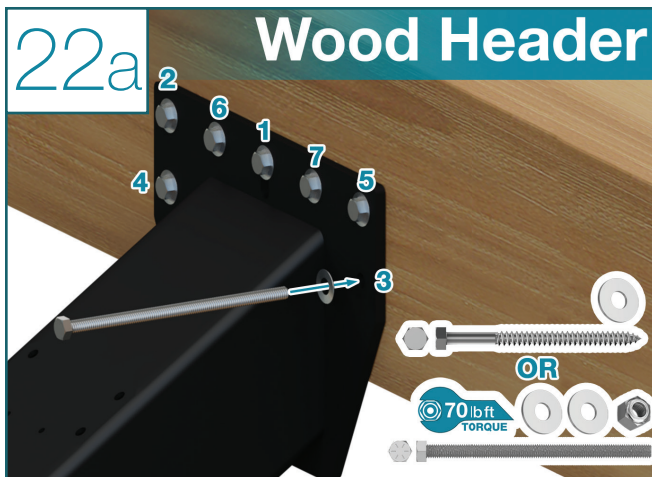

#### Upper Stringer Header Mount (2 mounting styles)

##### Through Bolt

- Thread the 1/2" x 8" hex head bolts into place, so they are finger tight
- Torque to 70 lb-ft

##### Lag Bolt

- Thread the 1/2" x 5" head lags into place

#### Upper Stringer Header Mount

- Refer to the recommendation of the brand of epoxy you are using and predrill the correct sized holes for these 1/2" threaded studs
- Apply concrete epoxy in to the holes
- Insert the threaded studs into each hole
- Torque to 50 lb-ft

Switchback Stringer Installation Steps (Continued)

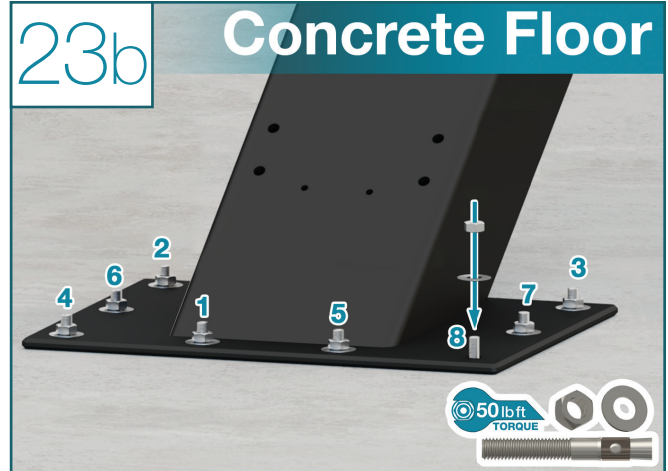
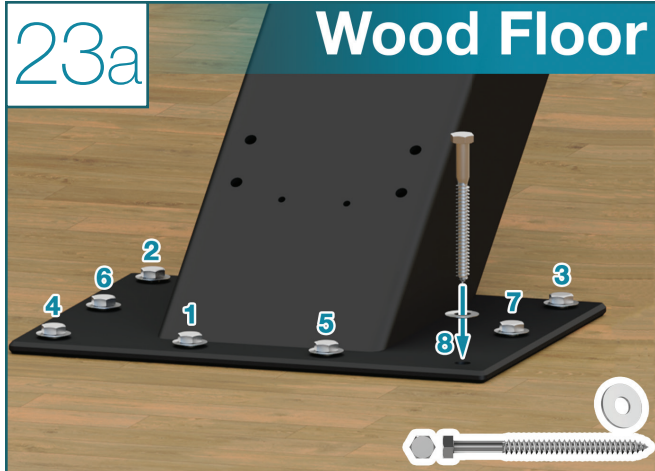

**Lower Stringer Floor Mount**

- Predrill your footer plate holes with a 3/8" drill bit
- Thread the 1/2" x 5" head lags into place

**Lower Stringer Floor Mount**

- Drill 1/2" holes for the concrete wedge anchors
- Insert a concrete wedge anchor into each hole
- Torque to 50 lb-ft



**Upper Bracket Cover Installation**

- Apply silicone sealant to the tops of the lags
- Carefully slide the cover over the wall plate

**Lower Bracket Cover Installation**

- Locate the lower bracket cover
- Apply silicon sealant to the tops of the lags or mounting hardware and install cover

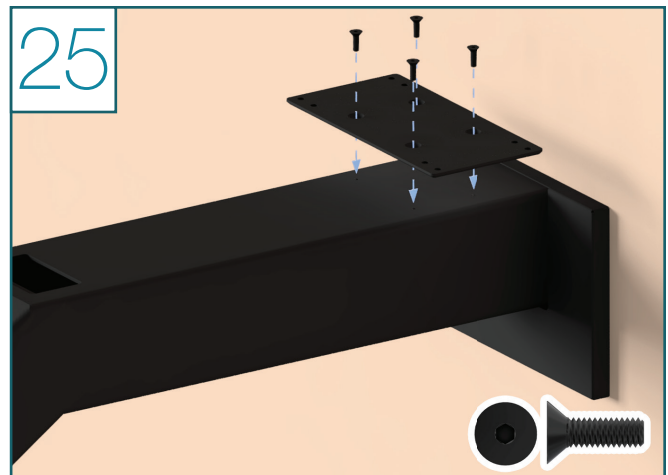

- Using 5/16" - 18 x 1" mount & attach the Landing Plates



### Switchback Stringer Installation Steps (Continued)

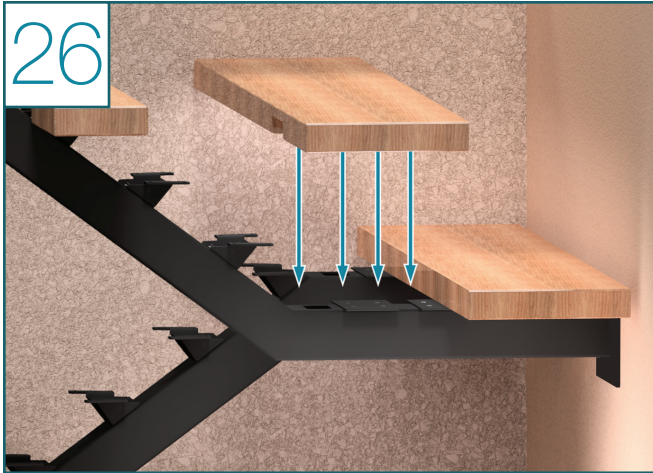

- Position the landing making sure that the platform lines up with the tread bracket and landing plates

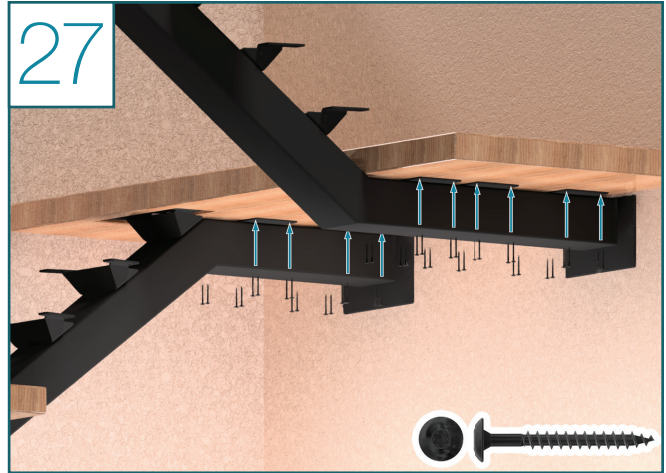

- Using the 5/16" x 2 1/2" RSS Screws, attach the platform to the landing plates
- During this step, alternate sides of the bracket when fastening screws. This will prevent the platform from pulling unevenly



- Next, identify your "first tread" on the lower stringer
- Using the 5/16" x 2 1/2" hanger bolts, populate the first tread holes



- Mount the first tread on to its tread plate
- The first tread mounts differently to the tread bracket than the rest of the treads

Switchback Stringer Installation Steps (Continued)



- Using a nut, tighten the tread to the tread bracket



- Repeat Steps 16-18 to fasten the remaining treads, one at a time, onto the tread brackets

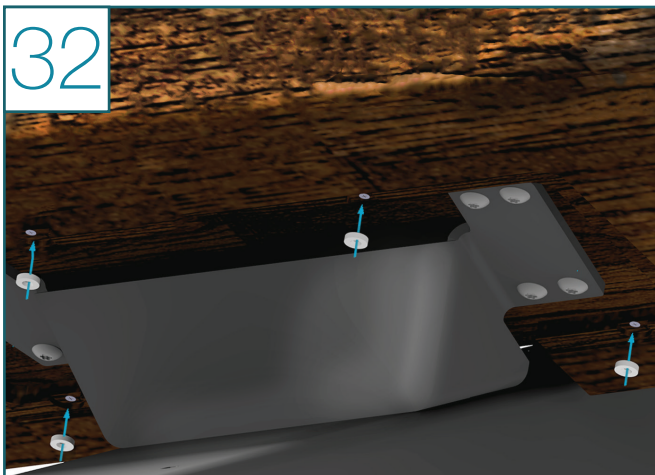

- Once your treads are in place, locate the tread bracket cover magnets and place all 4 magnets on the head of the magnet screws which are already factory installed (LED Treads will have 8 magnets)  
*Note: The magnets are strong enough to stick to the head of the screw and hold the tread bracket cover while the silicon (next step) dries.*
- The first tread will not typically receive a bracket cover and will not have the additional routing

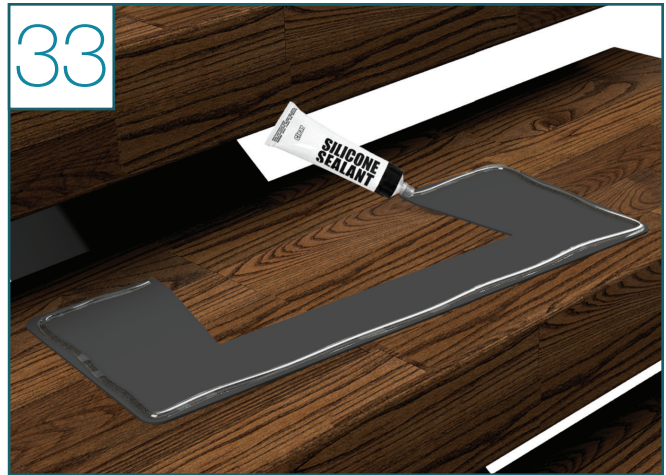

- Next find your tread bracket covers and lay them out.
- Locate and prep your silicone tube
- Run a bead of silicone around the edge of the tread cover, or the edge of the routed section on the tread, whichever you prefer

### Switchback Stringer Installation Steps (Continued)

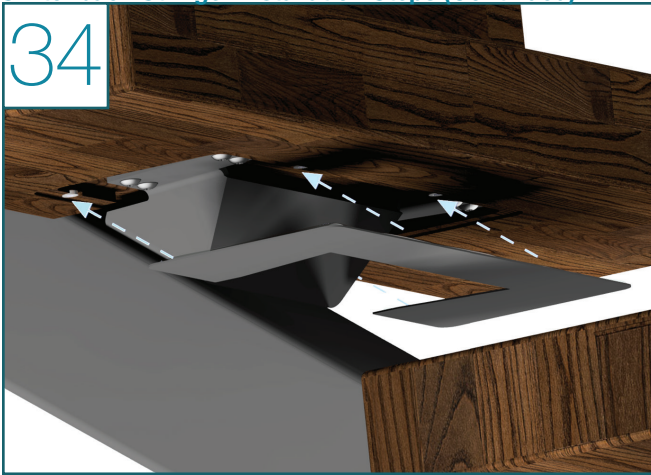

- Set the bracket cover in place. The magnets in the treads will hold the cover tightly, and the silicone will prevent rattling and create a tight fit
- Wipe off any excess silicone that might squeeze out

## Congratulations! You're done with this section.

We'd love to see your work! Snap a few pics with your phone and send them to [pictures@viewrail.com](mailto:pictures@viewrail.com). Thanks for choosing Viewrail. Enjoy your new installation!